

Ultra Compact CCD Colour Reverse Camera

#QVCM76

www.qvee.com.au



Comes with
pre-wired 1m connector

DESCRIPTION

The QVCM76 is an IP69K rated high quality compact colour CCD reverse camera. The CCD picture is of the highest quality and gives a true picture of your surroundings including accurate colours.

All of the QVEE cameras are compatible with either the 5.6" or 7" screens.

FEATURES

- Waterproof: IP69K rated
- Low profile design
- 10g anti vibration
- 8m night vision distance
- 120° viewing angle
- Compact size

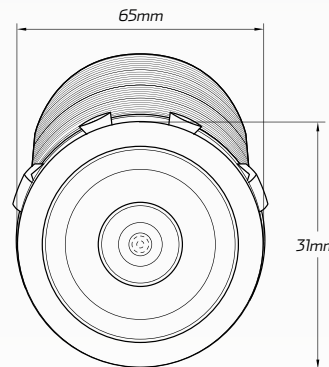

DIMENSIONS

- L: 65mm
- Ø: 31mm

TECHNICAL SPECIFICATIONS

Image Device	• 1/3" SHARP CCD
TV System	• PAL / NTSC
Effective Pixels	• 512 x 582px (PAL) / 512 x 492px (NTSC)
Sensing Area	• 4.9mm x 3.7mm
Scanning System	• 2:1 Interface
Gamma Consumption	• 0.45
S/N Ratio	• Better than 48dB
Electronic Shutter	• 1/60 (NTSC) / 1/50 (PAL) – 1/100,000 Sec
Storage Temperature	• -30° C – 80° C, RH 95% Max
Power Supply	• DC 12 V
Viewing Angle	• 120°
Minimum Illumination	• 0.1 Lux
Image Mode	• Mirror

Sync System	• Internal
Resolution	• 420 TV Lines
Horizontal Sync FQ	• 15.625 kHz (PAL) / 15.734 kHz (NTSC)
Vertical Sync FQ	• 50 Hz (PAL) / 60 Hz (NTSC)
Video Output	• 1.0 Vp-p, 75 Ohm
AGC	• Auto
White Balance	• Auto
BLC	• Auto
Operating Temperature	• -20° C – 60° C, RH 95% Max
Waterproof Rating	• IP69K
Audio	• No
Anti-Vibration	• 10 g
Heater	• No