

Amp Meter with Fixing Nut

#QVPSAMP

www.qvee.com.au



DESCRIPTION

The QVPSAMP is a heavy duty standard size amp meter.

Features a rugged design and green LED illumination. Suitable for automotive and marine use.

Comes supplied with fixing nut.

SOCKET TYPE



DIMENSIONS

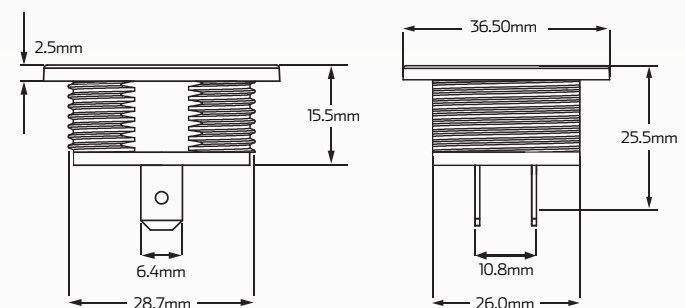

TECHNICAL SPECIFICATIONS

Input Voltage	• 12 - 24 Volt
Amp Meter Range	• 1A - 20A
Dimensions	• 25.5mm x 36.50mm
LED Indicator	• Green LED Illumination



Both surface and flush mounting panels available

APPLICATIONS

1	• Cars
2	• ATV's
3	• Trucks
4	• Recreational Vehicles
5	• 4 Wheel Drives
6	• Earthmoving Equipment
7	• Agricultural Machinery

SUITABLE QVEE MOUNTS

Part No.	Dimensions	Description
QVPSFMP1	• 43.22mm H x 61.31mm L x 4.3mm D	• Single flush mount panel
QVPSFMP2	• 43.34mm H x 107.3mm L x 4.3mm D	• Twin flush mount panel
QVPSFMP3	• 42.71mm H x 149mm L x 4.3mm D	• Triple flush mount panel
QVPSFMP4	• 85.38mm H x 103.2mm L x 4.3mm D	• 4 way flush mount panel
QVPSSMP1	• 50.54mm H x 55.91mm L x 81mm D	• Single surface mount panel
QVPSSMP2	• 50.46mm H x 98mm L x 76mm D	• Twin surface mount panel
QVPSSMP3	• 50.54mm H x 152mm L x 77mm D	• Triple surface mount panel