



97dB "Traditional" Sound Reverse Alarm

#QVRA688

www.qvee.com.au

DESCRIPTION

"Beep Beep" traditional sound reverse alarm. The QVEE beeper reverse alarm uses a traditional single frequency sound of a conventional alarm. Made from high quality nylon and fiber this alarm is water and dust proof. Ingress protection rating of IP66. Rated at 97dB this alarm is heavy duty and is ideal for application on a light vehicle and small trucks.



FEATURES

- Heavy duty backup alarm
- ABS housing
- SAE standard and E1 MARK of 10R
- Produces a powerful sound in reverse
- Sounder unit: speaker
- Water and dust proof - IP66

2
Year Warranty



TECHNICAL SPECIFICATIONS

DIMENSIONS

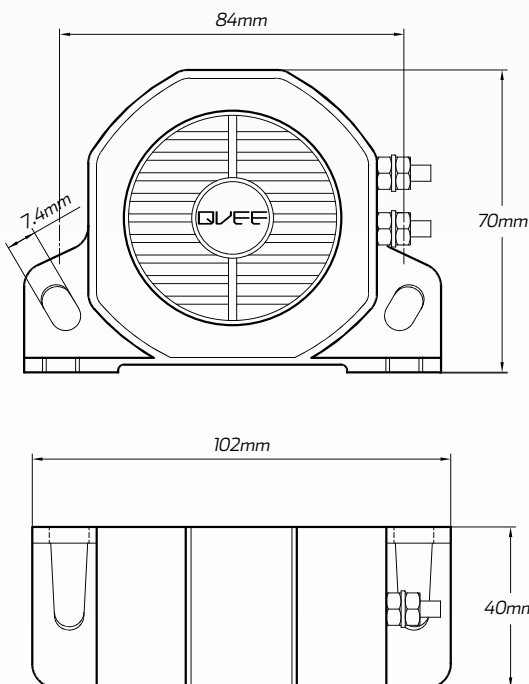

Voltage	• Multivolt 12 - 80 V DC
IP Rating	• IP66
Operating Amperage	• 0.3 Amp
Decibels @ 1m	• 97dB
Frequency	• 1250Hz +/- 100
Sounder Unit	• Speaker
Mechanical Vibration	• 10 G
Operating Temperature	• -40°C to 85°C
Dimensions	• 102mm W x 70mm H x 40mm L
Hole Centres	• 84mm
Approvals	<ul style="list-style-type: none"> • CE Certified • E1 MARK of 10R • SAE J994