



Dual Function Reverse Alarm

#QVRABW

www.qvee.com.au

DESCRIPTION

“Shhh Shhh” & “Beep Beep” dual function reverse alarm. Offers selectable noise between a standard ‘BEEP BEEP’ audio output at 102dB for daytime use or a white noise / squalker sounding alarm at 97dB for night time use based on wiring. Made from high quality nylon and fibre this alarm is water and dust proof with an ingress protection rating of IP66.



FEATURES

- Heavy duty dual function backup alarm
- Night time: Shhh Shhh sound @ 97dB
- Day time: Beep Beep sound @ 102dB
- Water and dust proof - IP66

2
Year Warranty



TECHNICAL SPECIFICATIONS

DIMENSIONS

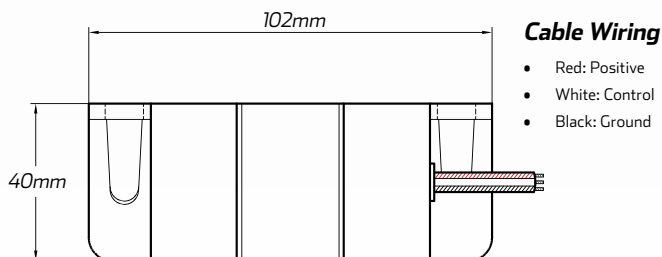
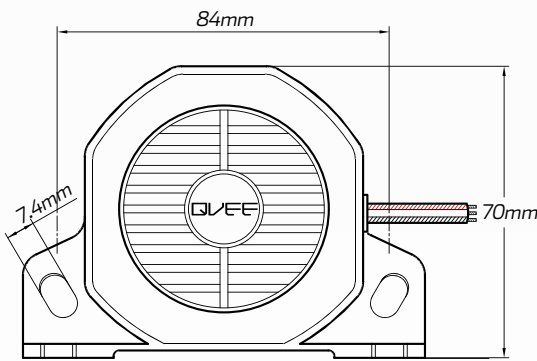

Voltage	• Multivolt 12 - 24 V DC
IP Rating	• IP66
Frequency	• 97dB / 102dB
Operating Temperature	• -40°C to 85°C
Dimensions	• 102mm W x 70mm H x 40mm L
Hole Centres	• 84mm
Function Mode Selection	• 3-Wire Version
Approvals	• CE Certified • SAE J994

FREQUENCY SPECIFICATIONS

	Traditional 'Beep Beep'	Squalker 'Shhh Shhh'
Decibels	• 102 +/- 4 dB	• 97 +/- 4 dB
Sound Cycles	• 65 per minute	• 73 per minute