

Heavy Duty LED Rotating Beacon

#QVRB162

www.qvee.com.au

DESCRIPTION

The QVRB162 is a 100mm x 165mm Diameter Heavy Duty CLASS 1 rated LED rotating amber beacon

Rugged design to suit all heavy duty applications including Mining, Transport, Shire, Traffic management etc.



TECHNICAL SPECIFICATIONS

LED Count	• 12 High Powered LED's	Mounting	• 3 Bolt Mount
Wattage	• 36 W	Colour	• Amber
Voltage	• 10 - 30 V DC	Lumens	• 1500 Lumens
IP Rating	• IP67 Rated	Dimensions	• 100mm H x 165mm D
Lens Construction	• Polycarbonate	Flash Patterns	• 6 different flash patterns including 4 unique alternate or simulated rotating flash patterns
Base	• Die - Cast		

FLASH PATTERN

1.	• Rotate - 120 fpm
2.	• Rotate - 85 fpm
3.	• Single Flash
4.	• Double Flash
5.	• Quad Flash
6.	• 2 - 3 - 4 - 5 Combined

DIMENSIONS

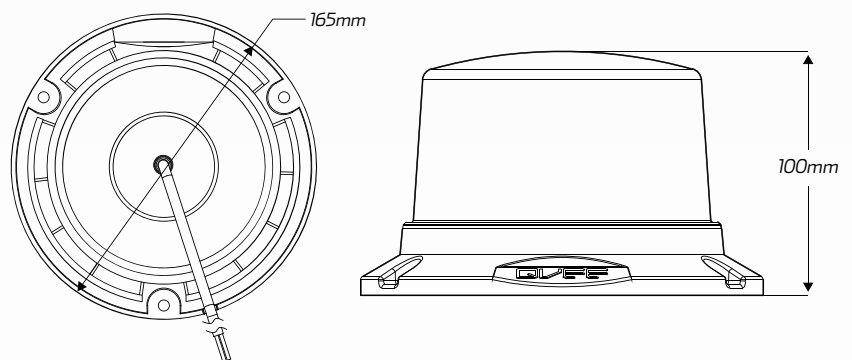

WIRING DESIGNATION

