



Heavy Duty Slimline LED Emergency Beacon

#QVRB420

www.qvee.com.au



DESCRIPTION

The CLASS 1 SAE & ECE R65 rated QVRB420 has a very slim low profile design. Like most light vehicles, height restrictions can be an issue when mounting emergency lighting.

The QVRB420 provides a solution to this problem without reducing lighting performance. Ideal for Mining, Transport, Shire & Traffic Management applications.

A great low profile solution.

TECHNICAL SPECIFICATIONS

LED Count	• 72 SMD LED's
Wattage	• 30 W
Voltage	• 10 - 30 V DC
IP Rating	• IP67 Rated
Material	• Polycarbonate Lens & Housing
Lumens	• 3,600 Lumens

Mounting	• 2 Bolts Mount
Approvals	• SAE Class 1 & ECE R65, R10
Wiring	• 500mm Sheathed
Dimensions	• 417mm x 200mm x 40mm
Flash Patterns	• Multiple flash patterns including 18 unique alternate or simulated rotating flash patterns

FLASH PATTERN

1. • Rotate - 150 FPM	11. • Burst Split
2. • Rotate - 75 FPM	12. • Random 1
3. • Center Out	13. • Single - Triple - Quin
4. • Steady on 30%	14. • Single H/L
5. • Single (ECE/SAE)	15. • Double Split - Quad Split
6. • Quad	16. • Random 2
7. • Burst	17. • Random 3
8. • Double Split	18. • Random 4
9. • Quad Split	
10. • Quin Split H/L	

DIMENSIONS

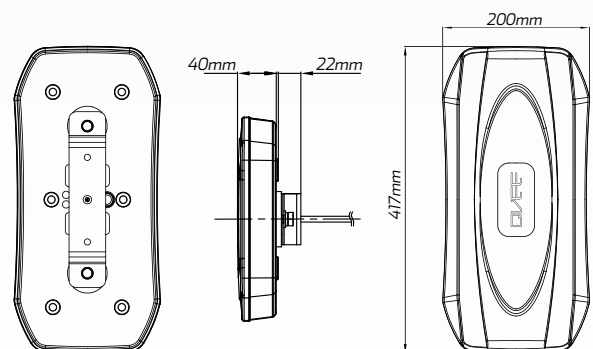

WIRING DESIGNATION

