



## Heavy Duty Warning Triangle

#QVST3P

www.qvee.com.au

### DESCRIPTION

The QVEE QVST3P Warning triangle is a heavy duty 3 piece set, fully compliant with the Australian Standard AS3790.

It incorporates optimised riveting; an additional metal plate between the back leg and the lining plate with optimised fitting clearance between the left and right lining plate.

Ideal for Light vehicles, trucks, 4WD's, buses or any emergency situation. Placement instructions are permanently printed on the outer box and safety triangles for ease of use.



### FEATURES

- Double sided reflectors
- Heavy duty weighted base
- Stabilising legs
- Easily folded for quick storage / usage
- Ideal for any emergency situation
- Instructions for both safety triangle and storage box
- Optimised clearance between left and right lining plate
- Optimised re-inforcing rib
- Metal plate added between black leg & lining plate



Optimised re-inforcing rib



Optimised clearance between left and right lining plate

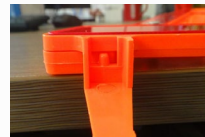

Metal plate added

### Comprises

- 3 x Safety triangle & base
- 1 x Heavy duty plastic case

### TECHNICAL SPECIFICATIONS

#### SAFETY TRIANGLE

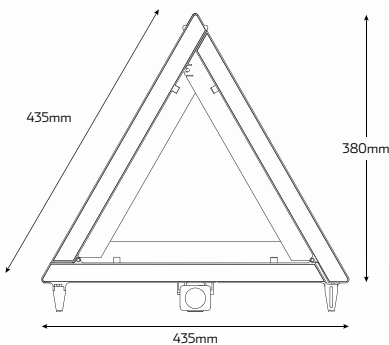

#### TRIANGLE BASE

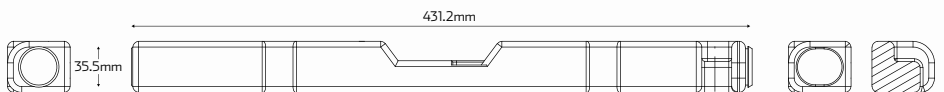

<b>Dimensions</b>	• 435mm L x 431.2mm D x 380mm H (416mm with base)
<b>Approvals</b>	• AS3790, FMVSS125, DOT Authenticated