



## Large Cat Style Circuit Breakers

#SDLM

www.mechprod.com

### DESCRIPTION

Large heavy duty manual reset circuit breakers.  
 Designed to protect wiring in the harshest environmental conditions.  
 Weatherproof and sealed against moisture and dust.  
 Fast response times to interupt overloads and short circuits.  
 Perfect for use in mining and agricultural equipment.



### TECHNICAL SPECIFICATIONS

<b>I.R</b>	• 2.5kA @ 14V DC, 1.5kA @ 28V DC
<b>Reset Mechanism</b>	• Manual Reset
<b>Housing</b>	• UL 94-V0 Black Thermoplastic
<b>Operating Temperature</b>	• -40° C to 85° C
<b>Ignition Protected</b>	• SAE J1171
<b>IP Rating</b>	• IP67 (Dust & Water), IP69K (Heat)
<b>Approvals</b>	• SAE J1625, J1171, ABYC E-11, • Mil-STD-202 (101, 106, 213), • Mil-STD-204

### DIMENSIONS

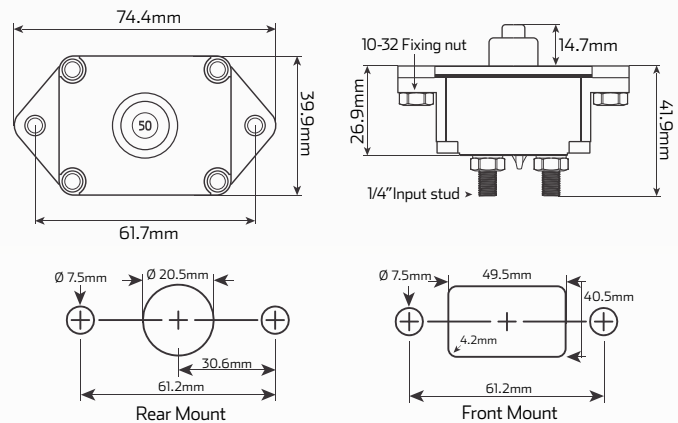

Recommended Mounting

### PART NUMBERS

Part No.	Amperage	Reset	Mount	Description
SDLM50	• 50 Amps	• Manual	• Panel Mount	• 50 Amp large heavy duty manual reset CAT style circuit breaker, panel mount
SDLM60	• 60 Amps	• Manual	• Panel Mount	• 60 Amp large heavy duty manual reset CAT style circuit breaker, panel mount
SDLM80	• 80 Amps	• Manual	• Panel Mount	• 80 Amp large heavy duty manual reset CAT style circuit breaker, panel mount
SDLM90	• 90 Amps	• Manual	• Panel Mount	• 90 Amp large heavy duty manual reset CAT style circuit breaker, panel mount
SDLM105	• 105 Amps	• Manual	• Panel Mount	• 105 Amp large heavy duty manual reset CAT style circuit breaker, panel mount
SDLM120	• 120 Amps	• Manual	• Panel Mount	• 120 Amp large heavy duty manual reset CAT style circuit breaker, panel mount
SDLM150	• 150 Amps	• Manual	• Panel Mount	• 150 Amp large heavy duty manual reset CAT style circuit breaker, panel mount