



24V 65A Continuous Duty PVC coated Solenoid

#24063-08

www.colehersee.com.au

DESCRIPTION

24V, 65A continuous duty solenoid with insulated earth stud and weatherproof PVC coating. 120A make and 65A break.

FEATURES

- Continuous duty solenoid
- SPST normally open (one circuit) OFF/ON
- Plated steel housing, hexnuts and washers included
- 4 stud, insulated earth stud
- Mount with brand cap facing "down"
- PVC coating, UL listed & ISO 8846 marine approved
- Copper contacts, Ignition protected

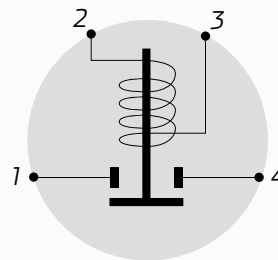

ELECTRICAL SCHEMATIC

Caution: never unscrew the inner hexnuts on the studs. These keep the stud and inner wiring in place.

TECHNICAL SPECIFICATIONS

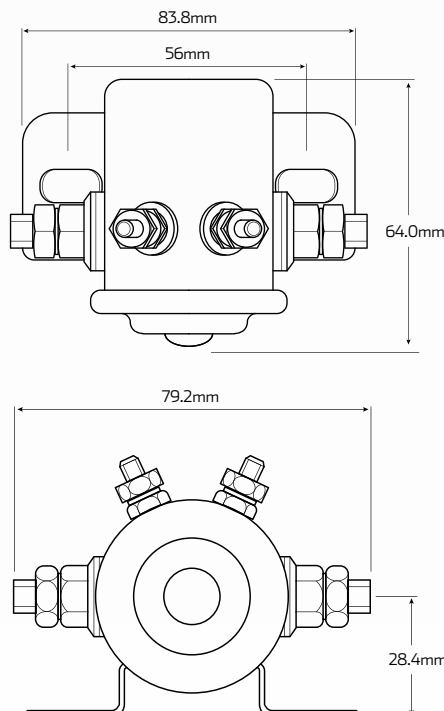

Voltage	• 24 Volt DC
Amperage	• 65 Amp continuous
Circuitry	• Single-Pole, Single-Throw (SPST)
Contacts	• Normally Open (NO)
Housing Material	• Plated steel, PVC coated
Contact Terminals	• Copper, Ignition protected
Battery Terminals	• 5/16" - 24 threads
Coil Studs	• 10 - 32" threads
Insulated / Grounded	• Insulated
Operating Temperature	• -40°C to 85°C
Bracket Mounting Holes	• 7.9mm x 15.1mm, 56.0mm CTC