

Emergency Stop Switch

#QVTMS02

www.qvee.com.au

DESCRIPTION

Plastic emergency stop switch with normally closed contact and normally open contact. Lid and contacts are fixed with actuator into the base to keep wiring within enclosure even when the lid is removed.

Telemecanique contacts. Twist to reset.



FEATURES

- Supplied with normally closed & normally open contacts
- IP65 dust and water protection rating
- Enclosed with metal thread & integral sealing basket
- Telemecanique 10A contact sets

DIMENSIONS

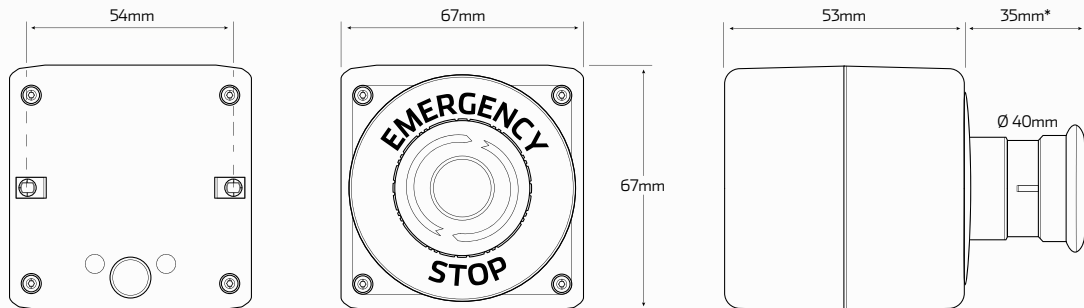

*When switch is at reset position

TECHNICAL SPECIFICATIONS

Contacts Function	• 1 x Normally closed, 1 x Normally open
Contact Rating	• 10Amp
Housing Material	• Plastic
Housing Colour	• Grey & yellow
Housing Dimensions	• 67mm W x 67mm H x 53mm D

Switch Material	• Plastic
Switch Colour	• Red
Switch Dimensions	• 40mm Ø x 35mm L @ reset
Mounting	• 4.3mm Ø, 54mm centre to centre
IP Rating	• IP65 rated